

MERRYFAIR®



AIRE

Seating Products



Elevate your workspace with Aire – where comfort, sustainability, and innovation converge seamlessly.

Lightweight Durability

Crafted to meet rigorous BIFMA standards, Aire embodies strength and durability without the bulk. Its lightweight design ensures easy maneuverability without compromising on quality.

Sleek Eco-Friendly Design

Aire's minimalist form reflects our commitment to sustainability. By paring down to the essential structure, we've minimized material usage, reducing environmental impact while enhancing aesthetic appeal.

Effortless Support

Experience personalized comfort with Aire's innovative auto-tension recline force. Designed to accommodate users of different weights, this feature is seamlessly integrated into the chair's structure, eliminating the need for complicated mechanisms.

Elevate Your Workspace

Transform your office into a haven of productivity and style with Aire. Whether you're typing away at your desk or engaging in a brainstorming session, Aire ensures optimal support and comfort for every task.

Why Choose Aire?

Lightweight yet robust construction for enhanced mobility and durability. Minimalist design reduces material usage, promoting eco-friendliness.

Auto-tension recline force accommodates users of different weights without complicated mechanisms.

Engineered to meet and exceed BIFMA standards for quality and safety.

Upgrade Your Workspace Today

Discover the perfect blend of comfort, sustainability, and innovation with Aire. Elevate your workspace experience and make the switch to Aire today.

Experience Aire: Redefining Office Comfort, Reinventing Sustainability.





Chair and mechanism in one minimalist structure

Experience comfort and sustainability in one seamless design with the Aire chair. Its innovative structure integrates a synchronized mechanism, reducing material usage while maintaining a sleek aesthetic. Eco-friendly and ergonomic, it boasts a 4-position angle limiter and auto-recline tension tailored to your body weight for the ultimate personalized experience.

Aire weighs less than 10kg yet fulfills BIFMA strength and durability requirements.





Frame in black.

Optional adjustable headrest.

Soft PU or 2-way adjustable PP arm-pads.

Safety & Durability

Aire is designed and certified to BIFMA X5.1 and EN-1335 standards for safety and durability. Longer lasting = less refuse

Recyclability

Aire is manufactured using up to 29% pre-consumer and 20% post-consumer material. At the end of life, up to 90% of Aire can be recycled.



Headrest

Optional headrest is adjustable for 45mm height range. Fiber-reinforced polyamide (100% recyclable) in black colour.

Chair Frame

Robust fiber-reinforced polyamide (100% recyclable) frame in black colour. Seat is adjustable for 12cm height.

Armrest

Armrest available in 2 options:

Soft touch armrest are molded from polyurethane foam in grey, and not adjustable.

2-way armrest in black polypropylene, adjusts for 6cm in depth and swivel into 3 angular positions.

Chair Mechanism

Featuring 4-position tilt limiter and auto-tilt tension. Bottom structure of diecast 100% recyclable aluminium alloy, finished in epoxy coating. Molded black polyamide (nylon) levers and steel hardware are recyclable.

Base

Five-prong base of fiber-reinforced polyamide (100% recyclable) in black. 50mm dual-wheel castors of molded polyamide (nylon).

High Back

1379B NAA88V

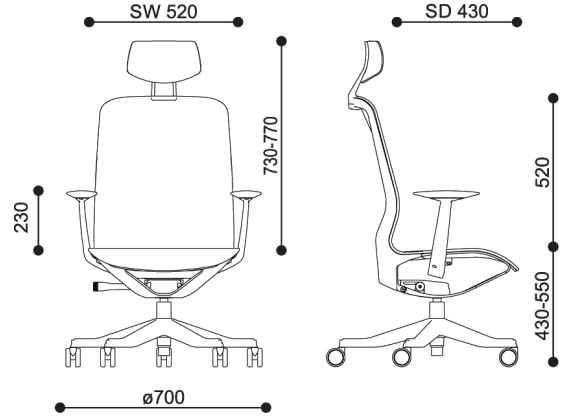

Mid Back

1378B NAA88V

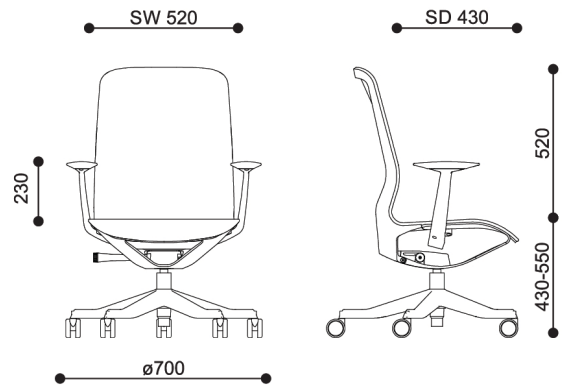

Aire: Options

Armpad



**2-way Adjustable
PP Armpad (Black)**
(A88)



**Fixed soft
PU Armpad (Grey)**
(A89)

Seat Features

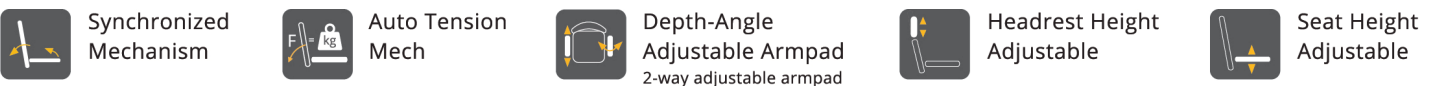

HEAD OFFICE & FACTORY

www.merryfair.com

Merryfair Chair System Sdn Bhd

(Co. No. 86276-A)
No.2, Jalan Koporat 1/KU9,
Taman Perindustrian Meru,
42200 Klang, Selangor D.E., Malaysia.

International Sales & Marketing

Tel. +603 3393 2888
Fax. +603 3393 2000
enquiry@merryfair.com

Domestic Sales & Marketing

Tel. +603 3393 6868
Fax. +603 3393 6888
domestic@merryfair.com

SHOWROOM OFFICE

Merryfair Marketing Sdn Bhd

(Co. No. 665054-V)
No. 82-84, Jalan 2/23A,
Jalan Genting Kelang,
53300 Kuala Lumpur, Malaysia.
Tel. +603 4149 8899
Fax. +603 4143 0113

REGIONAL OFFICE & SHOWROOM

美力菲 (中国) 家具有限公司

广东省佛山市顺德区容桂华口顺德高新区(容桂)华天路21号
邮编: 528306
Merryfair (China) Co.,Ltd
No. 21, Huatian Road, Shunde High Tech Industrial Zone
(Ronggui), Huakou Community, Ronggui Subdistrict,
Shunde District, Foshan City, Guangdong, China 528306.
Tel. +86 757 2636 9861
Fax. +86 757 2881 9700
domestic@merryfair.com.cn

Merryfair (Singapore) Pte Ltd

33 Ubi Avenue 3, #01-52/53 Vertex,
Singapore 408868.
Tel. +65 6284 9098
Fax. +65 6284 9028
enquiry@merryfair.com.sg

Merryfair (Thailand) Co., Ltd.

19/1-2 Sithakarn, Soi Chidlom
Lumpini, Pathumwan
Bangkok 10330 Thailand
Tel : +66 2254 1588
Fax : +66 2254 1585
sales@merryfair.co.th



MERRYFAIR reserves the right to introduce modifications and withdraw models for continuous improvements without prior notice.