

MERRYFAIR®



**BOBA**

Seating Products

Boba - the modern cushion swivel office chair with pre-loaded height-adjustable backrest and armrest for effortless adjustment. Crafted with the user's comfort in mind, this chair is designed to adapt to your needs seamlessly.

Experience superior comfort and support with the unique pre-loaded mechanism that allows the height of the backrest and armrest to be adjusted in one smooth motion. The self-weight balance mechanism takes ergonomics to the next level by using your body weight as the counterbalance, ensuring a perfect tilt every time.

Take your home office to the next level with this versatile and stylish chair. Elevate your workspace with the modern cushion swivel office chair and enjoy a perfect blend of functionality, comfort, and style.





### Finishing

Precise, evenly spaced stitches that create a clean and professional look. This type of stitching adds a touch of elegance and sophistication to the cushion, emphasizing the craftsmanship and quality of the piece. The single stitching serves not only as a decorative element but also as a functional one, ensuring durability and longevity of the cushion.

### Mechanism

Auto weight-sensing synchronized mechanism features 3-position tilt lock and pneumatic seat control. Meaning no tension adjustment is needed and the mechanism will use your weight as a counterbalance.

### Back height adjustment

Adjusting the armrests and backrest simultaneously saves time and makes it easier for users to quickly find a comfortable sitting position without the need for separate adjustments. This can help in maintaining a balanced posture and reducing strain on one side of the body.







### Backrest

Upholstered over high density polyurethane foam.

### Arm Frame

Features with synchronized back and arm height adjustment.

### Seat

Upholstered over high density polyurethane foam with 50mm seat slide adjustment.

### Mechanism

Auto weight-sensing synchronized mechanism features 3-position tilt lock and pneumatic seat height control.

### Base

Standard N2 base is moulded of polypropylene plastic (100% recyclable) in black colour.



50mm seat depth adjustment.



Easy glide backrest and armrest height adjustment.

**Safety and ergonomics**

Meet and certified BIFMA X5 and EN-1335 standards for safety and durability.

**Minimal to nature impact**

Almost all components of this chair are recyclable. By making the majority of the chair's components recyclable, we aim to minimize waste and promote sustainability. This approach not only benefits the environment by reducing the amount of material that ends up in landfills but also encourages responsible consumption and production practices.

**Mid Back**

**1328 YM A86 N2**

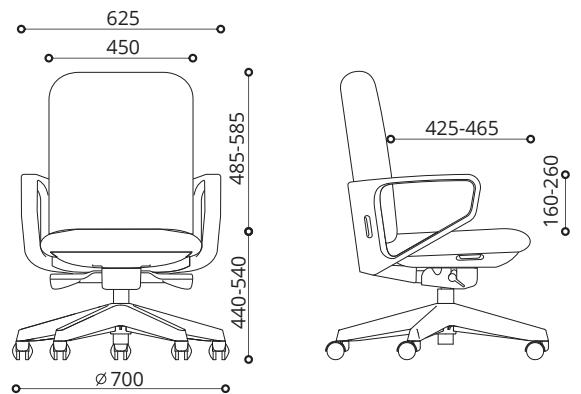

**Boba: Features**

**Armrest**



**Height Adjustable Armrest**

(A86)

**Mechanism**



**Weight-Sensing mechanism with Tilt lock**

(YM)

**Base**



**700mm Polypropylene base**

(N2)

**Seat Features**



Pneumatic Seat Height Adjustment



Sliding Seat



Height Adjustable Backrest and armrest



Synchronized Mechanism

## HEAD OFFICE & FACTORY

**Merryfair Chair System Sdn Bhd**  
(Co. No. 86276-A)  
No.2, Jalan Koporat 1/KU9,  
Taman Perindustrian Meru,  
42200 Klang, Selangor D.E., Malaysia.

**International Sales & Marketing**  
Tel. +603 3393 2888  
Fax. +603 3393 2000  
enquiry@merryfair.com

**Domestic Sales & Marketing**  
Tel. +603 3393 6868  
Fax. +603 3393 6888  
domestic@merryfair.com

[www.merryfair.com](http://www.merryfair.com)

## SHOWROOM OFFICE

**Merryfair Marketing Sdn Bhd**  
(Co. No. 665054-V)  
No. 82-84, Jalan 2/23A,  
Jalan Genting Kelang,  
53300 Kuala Lumpur, Malaysia.  
Tel. +603 4149 8899  
Fax. +603 4143 0113

## REGIONAL OFFICE & SHOWROOM

**美力菲 (中国) 家具有限公司**  
广东省佛山市顺德区容桂华口顺德高新区(容桂)华天路21号  
邮编: 528306  
Merryfair (China) Co.,Ltd  
No. 21, Huatian Road, Shunde High Tech Industrial Zone  
(Ronggui), Huakou Community, Ronggui Subdistrict,  
Shunde District, Foshan City, Guangdong, China 528306.  
Tel. +86 757 2636 9861  
Fax. +86 757 2881 9700  
domestic@merryfair.com.cn

**Merryfair (Singapore) Pte Ltd**  
33 Ubi Avenue 3, #01-52/53 Vertex,  
Singapore 408868.  
Tel. +65 6284 9098  
Fax. +65 6284 9028  
enquiry@merryfair.com.sg

**Merryfair (Thailand) Co.,Ltd.**  
19/1-2 Sithakarn, Soi Chidlom  
Lumpini, Pathumwan  
Bangkok 10330 Thailand  
Tel : +66 2254 1588  
Fax : +66 2254 1585  
sales@merryfair.co.th

MERRYFAIR reserves the right to introduce modifications and withdraw models for continuous improvements without prior notice.

