

MERRYFAIR®



FILA

Seating Products

Seating Excellence at Work

The Fila chair is a versatile, multi-purpose seating solution ideal for hotels, conventions, banquets, and events. It is designed to accommodate a large number of seats and can be quickly stored away after use.



Polypropylene Shells

Robust and Versatile Seating Solution:

Durable and Soil-Resistant

Engineered for rigorous outdoor use, with a hard-wearing surface that resists dirt and stains.

Customizable Color Options

Choose different colors for the seat shell and back to craft distinct and eye-catching color combinations. Alternatively, select uniform muted colors for a more streamlined appearance.

Drainage Hole

Models 883 & 887 include a drainage hole to effectively clear rainwater from the seat.

Padded Textile

Comfort and Texture:

Warmth and Coziness

The design feel, enhanced by its organic texture.

Enhanced Padding

The seat pad features clever shaping to provide extra thickness and comfort.

Easy Maintenance

Seat and back pads can be effortlessly removed and replaced using screw and Velcro fastenings, requiring no special skills or tools.





Effortless Assembly and Sleek Aesthetics:

Quick, Tool-Free Setup

Legs interlock seamlessly in seconds without the need for tools or additional brackets.

Unified Look

Overlapping design makes the legs appear as a single, cohesive unit, reducing visual clutter and enhancing the chair's sleek profile.

Fila's innovative Ready-Link legs allow for fast and seamless chair connections.



Optional Upholstery

Upholstered with polyurethane cut foam, which is recyclable into carpet padding, wadding, and other materials.

Main Shell

Injection-molded shell in white or charcoal (100% recyclable).



'Ready Link' Leg Base

Crafted from durable, glass fiber-filled polyamide (Nylon) in a charcoal color, the single-piece design of the legs enables easy ganging and stacking.



Optional Seat Shell

Injection-molded polypropylene in choice of 5 standard colours (100% recyclable).



Main Shell

Injection-molded glass fiber filled polypropylene shell in white or charcoal (100% recyclable).

Optional Upholstery

Upholstered with polyurethane cut foam, which is recyclable into carpet padding, wedding, and other materials.



Optional Leg Base

Mild steel framework, finished in silver-colour epoxy coating.

PP Seat and Back
883PNAA00HL



Padded Seat, PP Back
884PNAA00HL



Padded Seat and Back
885PNAA00HL

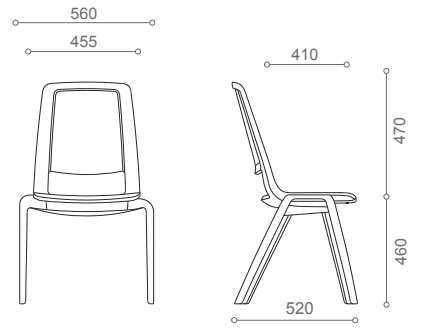

PP Seat and Back
887PNAA00HL



Padded Seat, PP Back
888PNAA00HL

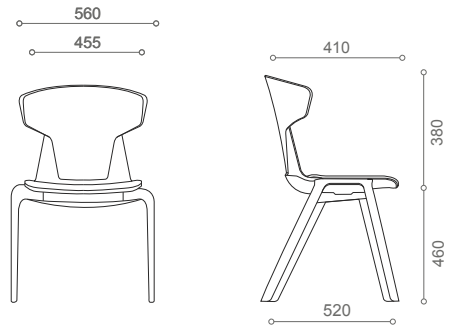

PP Shell
1333PNAA00HL



Padded Seat
1334PNAA00HL

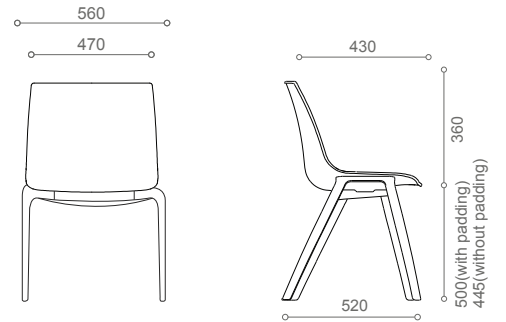

PP Main Colour



White



Charcoal

PP Seat Colour



Mango



Red



Olive



Green



Charcoal

Fila: Options

4 Leg

1333PNAA00H

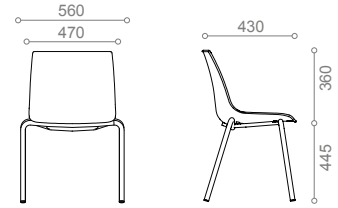

Sled Leg

1333PNAA00Y

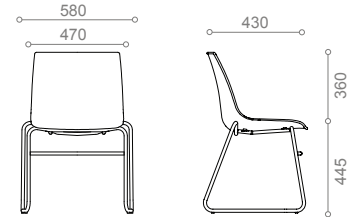

Reverse Cantilever

1333PNAA00Z

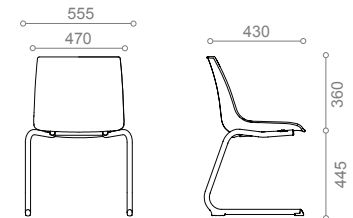

4 Leg Bar Chair

1333PNAA00HH

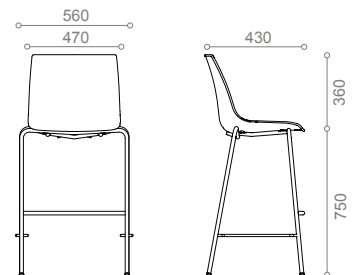

Swivel Chair

1333PHBA00M3

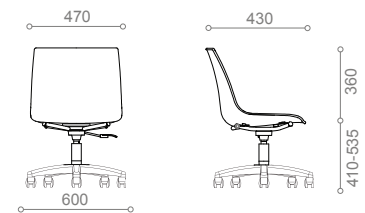

Accessories



A trolley made from welded mild steel tubes and bars, coated with black epoxy powder. It has castors with nylon hubs and rubber wheels, each rated to 75kg.



The trolley lifts a stack of 10 Fila chairs off the ground.

T3

HEAD OFFICE & FACTORY

www.merryfair.com

Merryfair Chair System Sdn Bhd

(Co. No. 86276-A)
No.2, Jalan Koporat 1/KU9,
Taman Perindustrian Meru,
42200 Klang, Selangor D.E., Malaysia.

International Sales & Marketing

Tel. +603 3393 2888
Fax. +603 3393 2000
enquiry@merryfair.com

Domestic Sales & Marketing

Tel. +603 3393 6868
Fax. +603 3393 6888
domestic@merryfair.com

SHOWROOM OFFICE

Merryfair Marketing Sdn Bhd

(Co. No. 665054-V)
No. 82-84, Jalan 2/23A,
Jalan Genting Kelang,
53300 Kuala Lumpur, Malaysia.
Tel. +603 4149 8899
Fax. +603 4143 0113

REGIONAL OFFICE & SHOWROOM

美力菲 (中国) 家具有限公司

广东省佛山市顺德区容桂华口顺德高新区(容桂)华天路21号
邮编: 528306
Merryfair (China) Co.,Ltd
No. 21, Huatian Road, Shunde High Tech Industrial Zone
(Ronggui), Huakou Community, Ronggui Subdistrict,
Shunde District, Foshan City, Guangdong, China 528306.
Tel. +86 757 2636 9861
Fax. +86 757 2881 9700
domestic@merryfair.com.cn

Merryfair (Singapore) Pte Ltd

33 Ubi Avenue 3, #01-52/53 Vertex,
Singapore 408868.
Tel. +65 6284 9098
Fax. +65 6284 9028
enquiry@merryfair.com.sg

Merryfair (Thailand) Co.,Ltd.

19/1-2 Sithakarn, Soi Chidlom
Lumpini, Pathumwan
Bangkok 10330 Thailand
Tel : +66 2254 1588
Fax : +66 2254 1585
sales@merryfair.co.th

