

MERRYFAIR®



FORTE

Seating Products

Seating Excellence at Work

FORTE, is the latest ergonomic seating model by Merryfair to provide a proper support during office routine.



Comfort

Forte complies to EN-1335 standard ensuring a comfortable fit to all sizes of user.

Flexibility

Use of optimum material and a streamlined back frame design allows your upper back to move freely during tasking.

Sustainability

All the parts except the upholstery and foam padding are recyclable at the end of product life cycle.



Forte is made and designed to conform to relevant international standards.

Headrest

A step-less height adjustable (75mm range) sleek headrest gives optimal support to the user.

Polyester Mesh

Provides elastic support, yet allowing ventilation for airy comfort.

Armrest

3-way adjustable A78 armrest can adjust for 100mm height range. Fiber-reinforced polyamide material (100% recyclable) in black colour.

Armpads can move forward or back and swivels into 3 angular positions to allow the user to rest their arms easily. Polypropylene material (100% recyclable) in black colour.

Base

Standard base is moulded of polypropylene in black colour. 50mm dual-wheels castor of moulded polyamide (Nylon).



Backrest

Slim back frame design is made of black polyamide plastic.

Lumbar Pad

Height-adjustable (65mm range) lumbar support range fits comfortably to the curve of your back to provide additional support for you lower back.

Seat

Seat consist of moulded polyurethane foam on a 2-piece shell structure, injection-moulded in back polypropylene. Seat depth is adjustable for 60mm by sliding seat and controlled by lever. Seat height is adjustable for 100mm by means of a pneumatic gas spring.

Mechanism

A weight-sensing mechanism auto-adjusts recline resistance according to user weight. Provides 3-position Tilt-Lock, Seat Height and Seat Depth Adjustment.

**Swivel-Tilt Chair
High Back with Headrest**
969 YM A78 N2

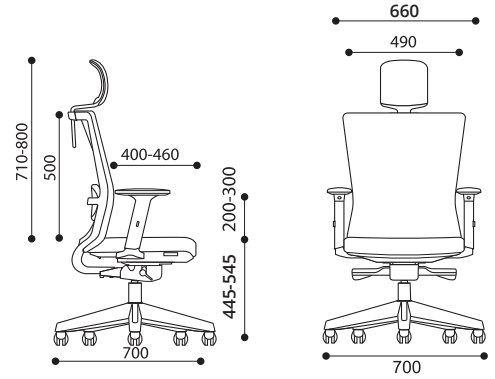
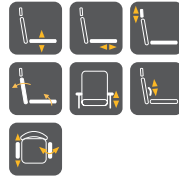

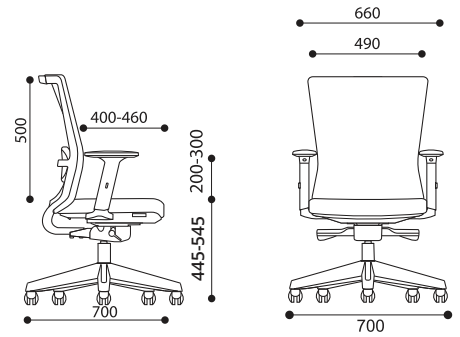

**Swivel-Tilt Chair
Mid Back**
968 YM A78 N2

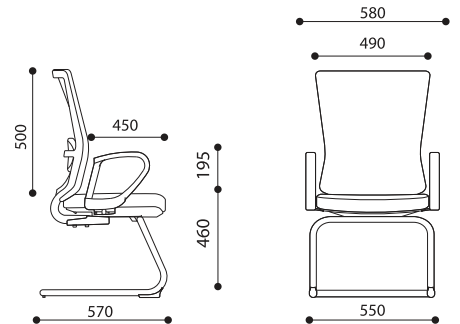

**Visitor Chair
with Cantilever Base**
961 NA A15 B





 Pneumatic Seat Height Adjustment

 Adjustable Seat Depth

 Height Adjustable Headrest

 Synchro Mechanism

 Height Adjustable Lumbar Support

 Depth - Angle Adjustable Armpad
2-way adjustable armpad

 Height Adjustable Armrest

Forte: Options

Armrest



3-Way Armrest with PP
Armpad
(A78)



3-Way Adjustable Armrest
with PU Armpad
(A69)



Fixed Armrest
(A15)

Base



350 Polished
Aluminium Base
(NP)



350 Studio Base
(N2)



Cantilever Base
(B)

HEAD OFFICE & FACTORY

Merryfair Chair System Sdn Bhd
(Co. No. 86276-A)
No.2, Jalan Koporat 1/KU9,
Taman Perindustrian Meru,
42200 Klang, Selangor D.E., Malaysia.

International Sales & Marketing
Tel. +603 3393 2888
Fax. +603 3393 2000
enquiry@merryfair.com

Domestic Sales & Marketing
Tel. +603 3393 6868
Fax. +603 3393 6888
domestic@merryfair.com

SHOWROOM OFFICE

Merryfair Marketing Sdn Bhd
(Co. No. 665054-V)
No. 82-84, Jalan 2/23A,
Jalan Genting Kelang,
53300 Kuala Lumpur, Malaysia.
Tel. +603 4149 8899
Fax. +603 4143 0113

REGIONAL OFFICE & SHOWROOM

美力菲 (中国) 家具有限公司
广东省佛山市顺德区容桂华口顺德高新区(容桂)华天路21号
邮编: 528306
Merryfair (China) Co.,Ltd
No. 21, Huatian Road, Shunde High Tech Industrial Zone
(Ronggui), Huakou Community, Ronggui Subdistrict,
Shunde District, Foshan City, Guangdong, China 528306.
Tel. +86 757 2636 9861
Fax. +86 757 2881 9700
domestic@merryfair.com.cn

Merryfair (Singapore) Pte Ltd
33 Ubi Avenue 3, #01-52/53 Vertex,
Singapore 408868.
Tel. +65 6284 9098
Fax. +65 6284 9028
enquiry@merryfair.com.sg

Merryfair (Thailand) Co.,Ltd.
19/1-2 Sithakarn, Soi Chidlom
Lumpini, Pathumwan
Bangkok 10330 Thailand
Tel : +66 2254 1588
Fax : +66 2254 1585
sales@merryfair.co.th

www.merryfair.com

